

Moderna COVID-19 Vaccine Recall Investigation Report – October 2021

Purpose and Intent

This document provides an overview of the investigations related to market complaints of stainless steel particles in unpunctured vials of a vaccine lot of Moderna's COVID-19 vaccine provided to Japan. Working with the Ministry of Health, Labour and Welfare (MHLW), Moderna, the manufacturer, Moderna's European contract manufacturing organization, ROVI Pharma Industrial Services, S.A. in Spain, and Takeda, the Japan Marketing Authorization Holder (MAH) and authorized distributor, are in the process of conducting a thorough, comprehensive investigation. Aspects of the investigation are ongoing.

This document includes:

- Section 1: Background
- Section 2: Root Cause Analysis
- Section 3: Particle Analysis
- Section 4: Joint For-Cause Audit
- Section 5: Corrective and Preventive Actions Following the Root Cause Analysis and For-Cause Audit
- Section 6: Health Risk Assessment
- Section 7: Investigation of Deaths Following Administration of Vaccine
- Section 8: Conclusion

The roles and responsibilities for the different parties referenced in this document are as follows:

- Moderna developed the COVID-19 mRNA vaccine, is the Global Marketing Authorization Holder and has contracted with the third-party Contract Manufacturing Organization, ROVI, to supply at least 45 countries, one of which is Japan, and excluding the U.S. market. Moderna provides direct technical, manufacturing and quality oversight for ROVI operations and all product manufactured. MHLW, Takeda and Moderna have entered into a Japan supply agreement for the pandemic response.
- Takeda is the Marketing Authorization Holder in Japan and is responsible for shipping the product from Europe to Japan, ensuring receipt of a secure shipment that meets temperature requirements, receiving/reviewing all associated product lot materials,

submitting any protocols and dispositioning of each lot. Takeda audited and qualified Moderna. Takeda also actively participated in a Moderna-led focused audit of ROVI driven by the events described in this summary, also known as a For-cause audit.

- ROVI is a European pharmaceutical company specializing and engaging in the research, development, contract manufacturing and marketing of small molecules and biological specialties. It is currently participating in the sterile manufacturing of the Moderna COVID-19 mRNA vaccine to supply markets outside the United States. ROVI has six fully-invested production plants holding multiple Good Manufacturing Practice (GMP) and FDA certifications. The company provides contract manufacturing services for high-value-added injectable medicines, which are exported to more than 50 countries.

Note About the Product

On May 21, 2021, the Ministry of Health, Labour and Welfare (MHLW) of Japan granted special approval under article 14-3 of the Pharmaceuticals and Medical Devices Act for emergency use of Moderna's mRNA COVID-19 vaccine. Moderna's COVID-19 vaccine is authorized for emergency use in individuals aged 12 years and older.

Section 1: Background

On August 26, 2021, JST, Takeda suspended the use of three lots of Moderna's COVID-19 vaccine in Japan, in alignment with MHLW, following reports from vaccination sites of black particles observed in unpunctured vials. The complaints that prompted the suspension were isolated to batch number 3004667 (Lot 1), but a total of three lots manufactured in the same series were included in the suspension out of an abundance of caution (batches 3004667, 3004734 and 3004956; Lots 1, 2 and 3). Takeda, as the Japan Marketing Authorization Holder, recalled the three lots in consultation with the MHLW on September 2, 2021, JST. Moderna, as the Global Marketing Authorization Holder, was in full agreement with this decision. Three deaths were reported following vaccinations from Lot 2 (batch 3004734) – one of the three recalled lots, but not the one subject to product complaints about foreign particles in unpunctured vials.

Scope of the Recall Investigation Report

For reference, a total of five lots of the Moderna COVID-19 vaccine were manufactured at ROVI in the series under discussion. Those lots were manufactured in sequential order and were

identified with the following numbers:

- Lot 1 – 3004667
- Lot 2 – 3004734
- Lot 3 – 3004956
- Lot 4 – 3004957
- Lot 5 – 3004958

Lots 1, 2 and 3 of the Moderna COVID-19 vaccine (the lots that were part of the voluntary recall on September 2, 2021, JST) are the focus of this investigation report. Lots 4 and 5 remained at ROVI and were never released or distributed to any market.

Section 2: Root Cause Analysis

Overview of Findings

The investigation revealed that the root cause of the particles identified in Lot 1 was the friction of two pieces of stainless steel 316L installed in the stoppering station of the line due to an incorrect set up of the equipment during a manufacturing line changeover (converting the line from running one product to another product) that occurred immediately prior to Lot 1. The incorrect assembly before manufacture of Lot 1 was not resolved at a separate vial breakage intervention (as detailed below) by the line operator after the filling of Lot 3. This led to the issue persisting throughout the series of five batches. The incorrect assembly was due to human error specific to visually misjudging the precise 1mm gap between the star-wheel and the stopper. This issue had not occurred before.

The two pieces of the stoppering station are the “star-wheel” and a lateral part of the star-wheel called the “stopper feeding device.” These two elements feed and deliver the stoppers to the vials. There is a required gap of 1mm between the star-wheel and the stopper feeding device and the regulation of that gap is conducted visually. A proper alignment relies on the capability, qualification and experience of the person performing the setup. The figure below illustrates the source of the friction.

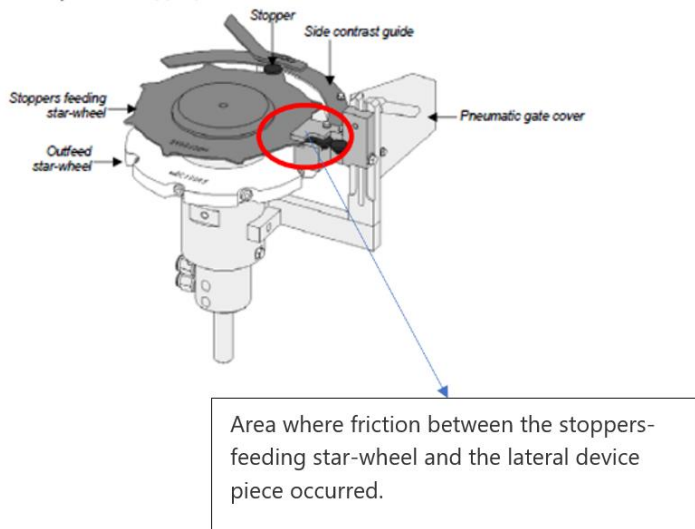

Additional Background on the Root Cause

The five lots were manufactured June 27 – July 3, 2021, CET in sequential order as listed in section 1 above. After the three recalled lots (Lots 1-3), two additional lots were produced in the same series: Lot 4 and Lot 5, both of which were held at the site by ROVI and were never released or distributed to any market, as described below.

Lot 4 failed the acceptable quality limit (AQL) inspection – a manual visual inspection done on a representative sample taken from the batch after passing 100 percent automatic visual inspection. This failure of the AQL inspection was due to the detection of particles on July 2, 2021, CET, which prompted an immediate investigation that included inspection of the filling line and a review of recent events on the line. That investigation identified that, after the filling of Lot 3, the operator running the line had to remove pieces of glass located at the base of the line, below the position of the star-wheel. That intervention was done on July 1, 2021, CET, in response to the vial breakage after the filling of Lot 3. The intervention involved the removal of the star-wheel and the stopper feeding device (illustrated above) to clear the line. At the time of this intervention, a plant mechanic was not available on site to complete the re-assembly of the equipment, therefore the line operator, who was not trained or qualified to re-assemble the equipment, conducted the work as instructed by a mechanic by phone.

The filling process of Lot 5 was in progress when Lot 4 failed the AQL and the decision was made to pause the filling of Lot 5. The inspection of the filling line at that time confirmed signs

of abrasion of the star-wheel and that the equipment parts had not been correctly assembled, leading to friction of the metal parts, which generated particles.

After the abrasion was observed, the star-wheel and stopper feeding device were removed once again from the line, cleaned, disinfected and re-assembled by the plant mechanic ensuring the correct assembly and verifying the required 1mm gap between the two elements. At that time, the filling of Lot 5 continued until complete. Lots 4 and 5 were investigated after Lot 4 failed inspection due to particles and were held at ROVI and never released or distributed to any market.

Rationale for Releasing Lots 1-3 After Holding Lots 4-5

As part of the urgent investigation requested by Takeda and conducted by ROVI and Moderna following the decision to suspend three lots in Japan, interviews with plant mechanics were conducted and there was a thorough review of visual inspection data. This investigation focused both on determining the nature of the particles observed and the root cause for the product complaints associated with Lot 1. That root cause analysis helped identify what likely happened as it relates to Lots 1, 2 and 3.

At the time of the Lots 4 and 5 investigation, ROVI determined and reported to Moderna that the abrasion occurred as a consequence of the intervention of the line operator due to the vial breakage event after filling Lot 3 and that the abrasion was limited to Lots 4 and 5. Therefore, the previous three lots had passed inspection and were not considered to be impacted by the incorrect star-wheel assembly that had occurred at the intervention.

Takeda was notified by Moderna on July 15, 2021, JST regarding the Lot 4 AQL failure and received the Lot 4 and 5 investigation results on July 18, 2021, JST. Takeda and Moderna had detailed discussions of the events and did not believe that the Lot 4 issue had impacted Lots 1, 2 and 3. Based on the information that was received, Moderna and Takeda decided that the lots were appropriate to release. Takeda received Lots 1 and 2 on July 21, 2021, JST and Lot 3 on July 28, 2021, JST with certified release documents from Moderna and ROVI.

On July 26, 2021, JST, Takeda met with the MHLW to report that Lots 4 and 5 would not be released and to discuss supply continuity. At the time of that meeting, Takeda did not believe

that there were any quality issues associated with Lots 1, 2 and 3 based on Moderna and ROVI's assessment and report.

This investigation indicates, however, that the issue was not limited to the intervention of the operator and reassembly of the star-wheel and stopper module that took place after filling Lot 3 and that impacted Lot 4 and Lot 5, as originally believed. The investigation points to a most probable root cause related to the inadequate set up of the star-wheel at the time of the line changeover on June 25, 2021, CET by a trained mechanic, which occurred prior to manufacturing Lot 1. On August 30 and September 1, JST, Takeda and Moderna presented the investigation status to the MHLW.

The investigation conducted and actions taken specific to the five lots confirm that no other lots were impacted by the equipment event described in this investigation report because the assembly line was used for products other than the Moderna vaccine immediately prior to the five lots manufactured and the equipment set up issue was corrected on July 2, 2021, CET before additional lots were manufactured.

Identification of Error and Determination of Scope of that Error

In summary, the incorrect assembly occurred as described above – at the changeover of the line by the plant mechanic before manufacture of Lot 1, which was not resolved at the vial breakage intervention by the line operator after Lot 3. This led to the issue persisting throughout the series of five batches. The incorrect assembly was due to human error specific to visually misjudging the precise 1mm gap between the star-wheel and the stopper.

It has been confirmed that such an issue had not occurred at ROVI prior to the incident with this five lot series and has not occurred since that time. This has been validated by the fact that there have been no reports of abrasion on the star-wheel prior to the five lot series. Furthermore, mechanic interviews, the lot automated visual inspection (AVI) performance data on previously manufactured lots, and a retrospective review of all batch records support the conclusion that the issue did not impact prior lots.

Moving forward, a new precision tool will help ensure that the star-wheel is assembled with the exact required 1mm gap. This is a positioning gauge that assures there is sufficient gap between the two metallic pieces and to avoid friction during the setup. Previous to this, and per the

manufacturer recommendations, the regulation of the height of the stoppers feeding device had been done visually. Furthermore, the standard operating procedure for changeover of the manufacturing line was improved and requires that only trained authorized mechanics perform all changeovers and interventions.

The immediate implementation of the in-process reject alert limit established following a historical statistical analysis of more than 100 lots of the Moderna COVID-19 vaccine, together with the other actions described in Section 5 below, have enhanced control of the manufacturing process and are closely assessed by the ROVI and Moderna Quality teams prior to disposition and approval of each lot going forward.

Section 3: Particle Analysis

Background on Quality Complaints

Takeda was first contacted regarding what appeared to be an isolated complaint of black particles identified in an unpunctured vial related to one of the three subsequently recalled lots over the weekend before August 16, 2021, JST. This product quality complaint included limited information, and a product complaint investigation was initiated. It is important to note that Takeda must validate any complaint and the company relies on vaccination centers to provide additional information and the sample vials. This is necessary for Takeda to make a reliable judgment on next steps.

Takeda subsequently received sample vials from one vaccination center, and additional complaints, and made the determination to report the issue to the MHLW. On August 25, 2021, Takeda, together with Moderna, reported the information to MHLW and, on August 26, 2021, JST, made the informed decision to suspend Lots 1, 2 and 3. The decision was based on product complaints concerning Lot 1, and although there were no product complaints concerning particle matter in unpunctured vials in Lots 2 and 3, these lots were included in the suspension out of an abundance of caution. Moderna immediately initiated a thorough investigation at Takeda's request.

Particle Analysis and Findings

Thirty-four unpunctured vials from Lot 1 that were received from various vaccination centers in Japan were transferred to Moderna's certified, independent third-party analytical laboratory for analysis. The analysis was complex and lengthy due to the small nature of the particles and various analysis methods applied. The analytical laboratory confirmed that the stopper of the vials was not punctured by the clinician or vaccine administrator.

The vial samples underwent optical image processing by microscopy to determine the presence and size of foreign particles. When the presence of foreign particles was confirmed, the particles were isolated from the vial through filtration or with a clean transfer pipette. They were then rinsed with deionized ultrafiltered (DIUF) water and each underwent optical imaging, stereomicroscopy and energy dispersive spectroscopy and scanning electron-microscopy. Microscopy results identified no particles in eight of the 34 vials.

Silver-colored, metallic-like particles were found in 24 of the 26 vials in which particles were identified. Elemental analysis confirmed that all silver-colored, metallic-like particles were grade 316L stainless steel (table below). Based on the microscopic and elemental analysis, the cause of the 316L stainless steel particles in the complaint vials is specific and isolated as described in Section 2.

Grade 316L is a high-quality grade of stainless steel commonly used in pharmaceutical and vaccine manufacturing.

Microscopy results showed that all 316L stainless steel particles in the tested vials ranged in size from approximately 22 x 15 microns to approximately 697 x 410 microns.

A picture of a representative silver-colored, metallic-like particle, measuring 238 x 133 microns, is provided below.

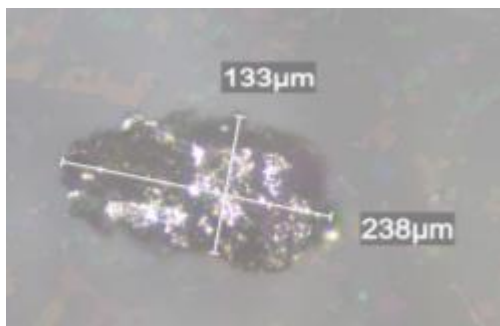

Lot 3004667 - Identification analysis of metallic particles in unpunctured vials (only particles for which elemental analysis was conducted are listed)

Sample #	Result	Approximate Measurement (Stereomicroscopy)
CI-28191	Grade 316 Stainless Steel (Fe-Cr-Ni-Mo)	238µm x 133µm
CI-28281	Grade 316 Stainless Steel (Fe-Cr-Ni-Mo)	418µm x 240µm
CI-28287	Grade 316 Stainless Steel (Fe-Cr-Ni-Mo)	517µm x 235µm
CI-28294	Grade 316 Stainless Steel (Fe-Cr-Ni-Mo)	334µm x 111µm
	Grade 316 Stainless Steel (Fe-Cr-Ni-Mo)	354µm x 96µm
CI-28295	Grade 316 Stainless Steel (Fe-Cr-Ni-Mo)	359µm x 198µm
CI-28283	Grade 316 Stainless Steel (Fe-Cr-Ni-Mo)	252µm x 190µm
CI-28284	Grade 316 Stainless Steel (Fe-Cr-Ni-Mo)	185µm x 161µm
CI-28285	Grade 316 Stainless Steel (Fe-Cr-Ni-Mo)	187µm x 126µm
CI-28286	Grade 316 Stainless Steel (Fe-Cr-Ni-Mo)	234µm x 195µm
CI-28288	Grade 316 Stainless Steel (Fe-Cr-Ni-Mo)	296µm x 193µm
CI-28289	Grade 316 Stainless Steel (Fe-Cr-Ni-Mo)	125µm x 89µm
CI-28290	Grade 316 Stainless Steel (Fe-Cr-Ni-Mo)	321µm x 235µm
CI-28291	Grade 316 Stainless Steel (Fe-Cr-Ni-Mo)	274µm x 158µm
CI-28292	Grade 316 Stainless Steel (Fe-Cr-Ni-Mo)	185µm x 97µm
CI-28297	Grade 316 Stainless Steel (Fe-Cr-Ni-Mo)	234µm x 208µm
CI-28300	Grade 316 Stainless Steel (Fe-Cr-Ni-Mo)	217µm x 59µm
CI-28301	Grade 316 Stainless Steel (Fe-Cr-Ni-Mo)	231µm x 203µm
CI-28305	Grade 316 Stainless Steel (Fe-Cr-Ni-Mo)	259µm x 142µm
CI-28307	Grade 316 Stainless Steel (Fe-Cr-Ni-Mo)	276µm x 225µm
CI-29309	Grade 316 Stainless Steel (Fe-Cr-Ni-Mo)	436µm x 172µm
CI-28311	Grade 316 Stainless Steel (Fe-Cr-Ni-Mo)	169µm x 109µm
CI-28312	Grade 316 Stainless Steel (Fe-Cr-Ni-Mo)	441µm x 290µm
CI-28313	Grade 316 Stainless Steel (Fe-Cr-Ni-Mo)	697µm x 410µm
CI-28314	Grade 316 Stainless Steel (Fe-Cr-Ni-Mo)	448µm x 246µm

Particles other than 316L stainless steel were identified in a total of five vials, including vials in which 316L stainless steel was identified. These are particles that, generally speaking, may occur in the process of manufacturing any injectable medicines. These particles are undergoing further investigation at ROVI, and Moderna will share a report with Takeda in accordance with standard reporting. Due to the particles' size and nature, there is no associated safety or efficacy risk.

According to the Moderna package insert label, healthcare providers are advised: "The Moderna COVID-19 vaccine is white to pale yellowish-white suspension. It may contain white or translucent product-related particles. Visually inspect the Moderna COVID-19 vials for other particulate matter and/or discoloration prior to administration. If either of these exists, the vaccine should not be administered."

A summary of the health risk assessment is in Section 6 below.

Section 4: Joint For-Cause Audit

A joint Moderna/Takeda For-cause audit was conducted at ROVI on September 1-2, 2021, CET. The focus of the audit was to confirm the investigation findings that had been reported, and the risk of particle generation and particle detection where the product lot was manufactured.

The findings included in the audit report identified the need for:

1. Changes to and reinforcement of equipment preventative maintenance to improve the state of the equipment.
2. Enhancement of particle detection capability during automated visual inspection (AVI).
3. Improvement of the Quality Operations manual visual inspection where AQL inspection occurs.

At this time, we have received the final report of the audit findings and we are awaiting the corrective and preventive action plan to improve the areas identified. ROVI and Moderna are fully committed to implementing corrective and preventative actions in consultation with Takeda.

A follow-up joint Takeda and Moderna audit is planned to take place following implementation of the actions described in Section 5.

Section 5: Corrective and Preventive Actions Following the Root Cause Analysis and For-Cause Audit

Note: The actions below will be updated with relevant additions from the final Corrective and Preventive Actions (CAPA) plan, as necessary.

The following actions are being taken by ROVI at the direction of Moderna, in consultation with Takeda, to correct and prevent future issues:

- Immediate and full inspection of the COVID-19 vaccines manufacturing line, including materials of construction for the associated equipment parts in this investigation.
- Improving standard operating procedures for changeover of the manufacturing line, including assurance that only trained authorized mechanics will perform all changeovers and interventions, combined with the utilization of a precision gauge to ensure the required 1mm gap (at top and bottom positions of that piece). This gauge will ensure more precise assembly.
- Improving the inspection line challenge set ups before and after lot use, to include new challenge samples based on line performance and historical experience.
- Improving the overall set up and controls for the AVI system ensuring that the line always operates within the approved parameters.
- Setting alert inspection limits in the AVI, as an internal process control, to include quality review.
- A full maintenance plan for the filling line and associated equipment will be conducted. This maintenance was conducted from September 12-25, 2021 CET, as part of the routine, scheduled plant shutdown.

Completion of the corrective and preventive actions will be directly overseen and confirmed by Moderna, in collaboration with Takeda.

Section 6: Health Risk Assessment

A medical assessment of possible safety risks associated with the grade 316L stainless steel particle was performed by Moderna and Takeda. The review included an evaluation of the

current investigation findings, the published literature, and a comprehensive analysis and assessment.

As stated above in Section 3, the chemical composition of the silver-colored, metallic-like particles in the vials from Lot 1 has been evaluated and confirmed to be 316L stainless steel. In all instances of injections, the size of the particle is a restricting attribute. The particle must be small enough (or non-rigid) to pass through the bore of the needle, i.e., the particle must be less than the internal diameter of the needle in at least two dimensions. The diameter of the hypodermic needle used to administer vaccines is approximately 260 microns. As stated above, approximate measurement of the 316L stainless steel particles in the tested vials were 22 x 15 to 697 x 410 microns. Therefore, it's unlikely that significant particles were injected based on the size of the samples tested.

Stainless steel, even if injected intramuscularly, is considered safe. Stainless steel is routinely used in medical applications: for example, in orthopedic implants, heart valves and pacemaker implants, and metal sutures and surgical staples. 316L stainless steel is considered non-corrosive under normal physiological conditions and approved for these uses due to its durability and chemical/biologic compatibility¹⁾.

Additionally, the amount of metal potentially deposited from an intramuscular injection is many orders of magnitude less than the exposure realized during implantation and surgical procedures. For example, a study demonstrated the deposit of over 500,000 particles and 1.13 mg of steel material from saw blades alone during a total knee arthroplasty simulated on pig knees⁸⁾. These amounts are well in excess of the miniscule quantity potentially injected with a small-volume vaccine administration. These surgical procedures are performed on millions of patients each year without incident.

For reference, toxicities from metallic elemental components are seen if and when the metals are present at sufficiently high concentrations to disturb normal biologic functions. 316L stainless steel is mainly composed of iron, chromium, nickel, molybdenum and manganese. These metals are elements necessary for the maintenance of vital functions^{1) 2)}. Chromium and manganese are trace elements present in total parenteral nutrition formulations³⁾. Humans are exposed to nickel daily through air, water and food, and the criteria for exposure are assessed and established by country (Japan⁴⁾ and United States⁵⁾).

If isolated metallic particles of the size identified from Lot 1 are injected into a muscle, it may result in a local reaction and the potential development of a local granuloma at the injection site ⁹⁾¹⁰⁾, but since the particles are very small, they are likely to have no clinical symptoms. A granuloma is an aggregation of white blood cells that forms in response to chronic inflammation ¹¹⁾. Such a reaction from a subvisible particle during a vaccine injection would be highly unusual and would not be considered to pose a medical risk.

Stainless steel particles similar to those found in the tested vials would not likely impact the efficacy of the vaccine. Stainless steel is a common contact material for mRNA vaccines due to its chemical inertness. High temperature reversed-phase high-performance liquid chromatography (HPLC) with a stainless steel column is widely used to purify mRNA from transcription reactions ¹²⁾. This purification step will cause little or no damage to the mRNA. In addition, the product buffered Lipid Nano Particles (LNPs) are in contact with multiple stainless steel surfaces in manufacturing during the formulation and filling/finishing process. Stainless steel particles are unlikely to adversely affect the integrity of RNA or LNP, and no impact of these fine particles on product quality is expected.

The risk of sterility deviations is very low because the 316L stainless steel from the stoppering process operates in the sterile filling area. The recalled lots also meet the sterility release criteria and container-closure integrity in-process control tests.

Given the small size of particles that can pass through the needle bore, the very low elution profile of metallic ions from 316L stainless steel under physiological conditions ⁶⁾ and the fact that humans are often exposed to the elemental components of 316L stainless steel without apparent health consequences ⁷⁾, it is considered highly unlikely that the inadvertent intramuscular administration of particles would pose a risk to health or life.

The available data and the safety analysis conducted to date on reported adverse events for the recalled lots provide no evidence to suggest health hazards associated with the presence of the silver-colored, metallic-like particles identified during this investigation. Based on this assessment, the rare presence of 316L stainless steel particles in the Moderna COVID-19 vaccine does not pose an undue risk to patient safety and it does not adversely affect the benefit/risk profile of the product.

1) United States Food and Drug Administration. Biological responses to metal implants. September 2019.

2) Yasuhiro Yamane: The role of trace elements in biological samples. [Health Physics 1990;25:269-277](#).

- 3) Btaiche IF, Carver PL, Welch KB. Dosing and monitoring of trace elements in long-term home parenteral nutrition patients. JPEN J Parenter Enteral Nutr. 2011;35:736-747.
- 4) Japan Ministry of the Environment, Review of environmental standards for the protection of human health related to water pollution. [Health risk assessment of nickel compounds](#). February 2004.
- 5) United States Environmental Protection Agency. Chemical Assessment Summary: nickel refinery dust. [Integrated Risk Information System \(IRIS\)](#)
- 6) Stockmann-Juvala H, Hedberg Y, Dhinsa NK, et al. Inhalation toxicity of 316L stainless powder in relation to bioaccessibility. Hum Exp Toxicol. 2013;32:1137-54.
- 7) Santonen T, Stockmann-Juvala H, and Zitting A. Review on toxicity of stainless Steel. ISBN 978-952-261-039-3
- 8) Gotterson PR, Nusem I, Pearcy MJ, Crawford RW. Metal debris from bony resection in knee arthroplasty--is it an issue? Acta Orthopaedica. 2005;76:475-80.
- 9) Elhelu MA. The role of macrophages in immunology. J Natl Med Assoc. 1983;75:314-317.
- 10) Klopffleisch R, Jung F. J Biomed Mater Res A. 2017;105:927-940.
- 11) Granulomas. Health Direct. Australian Health Ministry. <https://www.healthdirect.gov.au/granulomas>
- 12) Karikó K, Muramatsu H, Ludwig J, et. al. Nucleic Acids Res. 2011;39:e142.

Section 7: Investigation of Deaths Following Administration of Vaccine

At this time, there is no evidence that the three tragic deaths following administration of the Moderna COVID-19 vaccine from Lot 2 were in any way related to the vaccine. A formal, independent investigation to confirm the cause of death in these cases is ongoing and it is being conducted by the appropriate authorities with the greatest sense of urgency, transparency and integrity.

The review of these cases by an independent MHLW expert panel (Adverse Reaction Review Committee) on September 10, 2021, JST concluded that the causality between the vaccine and death is not assessable at this stage. As additional information becomes available, Takeda will immediately provide this information to Japanese health authorities (PMDA, MHLW) for further assessment. Currently, autopsy results for two of the three fatal cases have been obtained, both of which were considered sudden death due to fatal arrhythmia (cause of death).

Background on Incidence of Sudden Death in Japan

The three deaths known to have occurred following vaccination with doses from Lot 2 correspond to an incidence of 15.6 cases per 100,000 people annually. The estimated denominator in this analysis was based on assignment of a one-month risk window following vaccination for each of approximately 230,208 vaccine recipients per the number of doses used from Lot 2.

According to the Guidelines of the Japanese Circulation Society Joint Working Group ¹⁾, the number of sudden deaths in Japan is estimated to be about 50,000 per year. With this data and the Japanese population of 120 million people, the annual incidence of sudden death in Japan is estimated to be 41.7 per 100,000 people.

In the analysis of sudden death in Japan by gender and age group, the annual incidence in men aged 20 – 59 years was 8.0 to 89 per 100,000 people, which was higher than in women, and the incidence increased with age ²⁾. In the Japanese Circulatory Risk in Communities Study (CIRCS), the annual incidence of sudden cardiac death between 2001 and 2005 was 36.8 cases per 100,000. ³⁾ According to a 2010 systematic review on out-of-hospital cardiac arrest, the annual incidence rate in Japan was between 15.6 and 37.8 cases per 100,000 people ⁴⁾.

- 1) The Japanese Circulation Society. Guidelines for risks and prevention of sudden cardiac death (JCS 2010).
- 2) Tanabe N, et al. Epidemiological findings of sudden death in Japan. Jpn. J. Electrocardiology. 2006;26:111-117 (in Japanese)
- 3) Maruyama M, Ohira T, Imano H, et al. Trends in sudden cardiac death and its risk factors in Japan from 1981 to 2005: the Circulatory Risk in Communities Study (CIRCS) .BMJ Open 2012;2:e000573.
- 4) Berdowski J, Berg RA, Tijssen JGP, et al. Global incidences of out-of-hospital cardiac arrest and survival rates: Systematic review of 67 prospective studies. Resuscitation 2010;81:1479-1487

Section 8: Conclusion

Three lots of the Moderna COVID-19 vaccine were suspended while a preliminary investigation was performed following reports from the market of particles in unpunctured vials. The lots were then recalled on September 2, 2021, JST, in consultation with the MHLW. The analyses above informed the recall decision. The investigation conclusion and the actions taken to identify and correct the root cause have confirmed that the scope of the event was limited exclusively to the five lots referenced in this investigation report.

According to the root cause analysis report, the most probable cause of the particles identified in Lot 1 is related to friction between two pieces of metal installed in the stoppering module of the production line due to an incorrect set up.

In summary, the incorrect assembly occurred at the changeover of the line by the plant mechanic before manufacture of Lot 1, which was not resolved at the vial breakage intervention by the line operator after the filling of Lot 3. This led to the issue persisting

throughout the series of five batches. The incorrect assembly was due to human error specific to visually misjudging the precise 1mm gap between the star-wheel and the stopper. This issue had not occurred before. New corrective actions including improved standard operating procedures at the changeover and the utilization of a new precision tool will help prevent the risk of this issue reoccurring.

According to Moderna's certified independent third-party analytical laboratory, the silver-colored, metallic-like particles from Lot 1 have been thoroughly analyzed and are confirmed to be grade 316L stainless steel. Grade 316L is a high grade of stainless steel commonly used in pharmaceutical manufacturing and in food processing.

Finally, the health assessment conducted by Moderna and Takeda concluded that the rare presence of stainless steel particles in the Moderna COVID-19 vaccine does not pose an undue risk to patient safety and it does not adversely affect the benefit/risk profile of the product.

As of September 27, 2021, approximately 25 million doses of Moderna's COVID-19 vaccine have been administered in Japan and more than 200 million doses of the Moderna COVID-19 vaccine have been administered to more than 110 million individuals in 45 countries. The vaccine has a well-established safety and efficacy profile.

The Delta variant is further evidence of the dire need to ensure that we accelerate global vaccine distribution efforts, and continued public trust and confidence in the vaccine is essential. Takeda and Moderna are mobilized in an effort to ensure that the Moderna COVID-19 vaccine program continues to support millions of people in Japan and help the country fight this devastating pandemic.